

---

# HM51W16165B Series

# HM51W18165B Series

1048576-word × 16-bit Dynamic Random Access Memory

# HITACHI

ADE-203-541 (Z)

Preliminary

Rev. 0.0

Mar. 20, 1996

---

## Description

The Hitachi HM51W16165B Series, HM51W18165B Series are CMOS dynamic RAMs organized as 1,048,576-word × 16-bit. They employ the most advanced CMOS technology for high performance and low power. HM51W16165B Series, HM51W18165B Series offer Extended Data Out (EDO) Page Mode as a high speed access mode.

## Features

- Single 3.3 V ( $\pm 0.3$  V)
- High speed
  - Access time: 60 ns/70 ns/80 ns (max)
- Low power dissipation
  - Active mode: 468 mW/414 mW/360 mW (max) (HM51W16165B Series)  
: 666 mW/594 mW/540 mW (max) (HM51W18165B Series)
  - Standby mode : 7.2 mW (max)  
: 0.54 mW (max) (L-version)
- EDO page mode capability
- Long refresh period
  - 4096 refresh cycles : 64 ms (HM51W16165B Series)  
: 128 ms (L-version)
  - 1024 refresh cycles : 16 ms (HM51W18165B Series)  
: 128 ms (L-version)

Preliminary: This document contains information on a new product. Specifications and information contained herein are subject to change without notice.

This specification is fully compatible with the 16-Mbit DRAM specifications from TEXAS INSTRUMENTS.

---

## HM51W16165B Series, HM51W18165B Series

---

- 4 variations of refresh
  - $\overline{\text{RAS}}$ -only refresh
  - $\overline{\text{CAS}}$ -before- $\overline{\text{RAS}}$  refresh
  - Hidden refresh
  - Self refresh (L-version)
- 2CAS-byte control
- Battery backup operation (L-version)

### Ordering Information

Type No.	Access time	Package
HM51W16165BJ-6	60 ns	400-mil 42-pin plastic SOJ (CP-42D)
HM51W16165BJ-7	70 ns	
HM51W16165BJ-8	80 ns	
HM51W16165BLJ-6	60 ns	
HM51W16165BLJ-7	70 ns	
HM51W16165BLJ-8	80 ns	
HM51W18165BJ-6	60 ns	
HM51W18165BJ-7	70 ns	
HM51W18165BJ-8	80 ns	
HM51W18165BLJ-6	60 ns	
HM51W18165BLJ-7	70 ns	
HM51W18165BLJ-8	80 ns	
HM51W16165BTT-6	60 ns	400-mil 50-pin plastic TSOP II (TTP-50/44DC)
HM51W16165BTT-7	70 ns	
HM51W16165BTT-8	80 ns	
HM51W16165BLTT-6	60 ns	
HM51W16165BLTT-7	70 ns	
HM51W16165BLTT-8	80 ns	
HM51W18165BTT-6	60 ns	
HM51W18165BTT-7	70 ns	
HM51W18165BTT-8	80 ns	
HM51W18165BLTT-6	60 ns	
HM51W18165BLTT-7	70 ns	
HM51W18165BLTT-8	80 ns	

---

## Pin Arrangement

HM51W16165BJ/BLJ Series

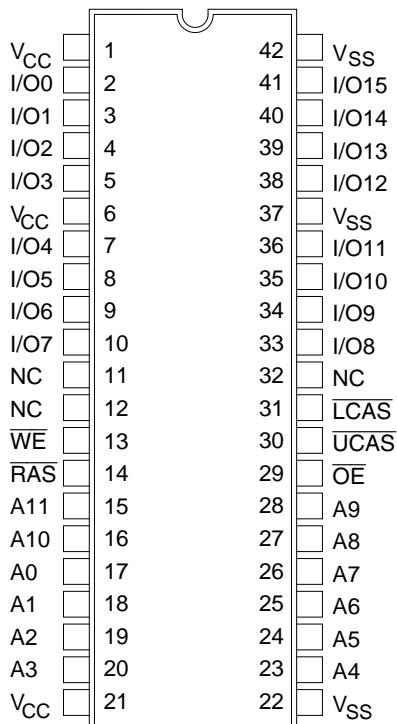

(Top view)

HM51W16165BTT/BLTT Series

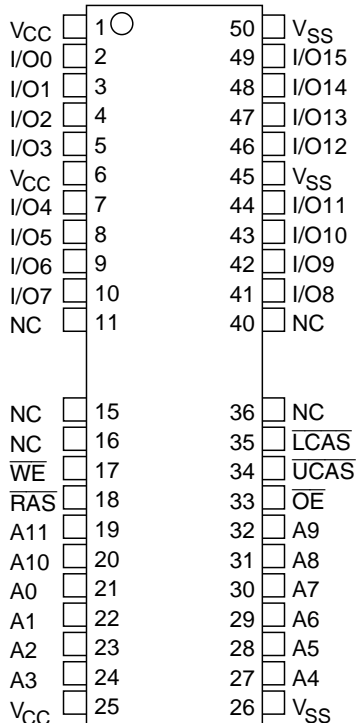

(Top view)

## Pin Description

Pin name	Function
A0 to A11	Address input — Row/Refresh address A0 to A11 — Column address A0 to A7
I/O0 to I/O15	Data input/Data output
RAS	Row address strobe
UCAS, LCAS	Column address strobe
WE	Read/Write enable
OE	Output enable
V <sub>CC</sub>	Power supply
V <sub>SS</sub>	Ground
NC	No connection

# HM51W16165B Series, HM51W18165B Series

## Pin Arrangement

HM51W18165BJ/BLJ Series

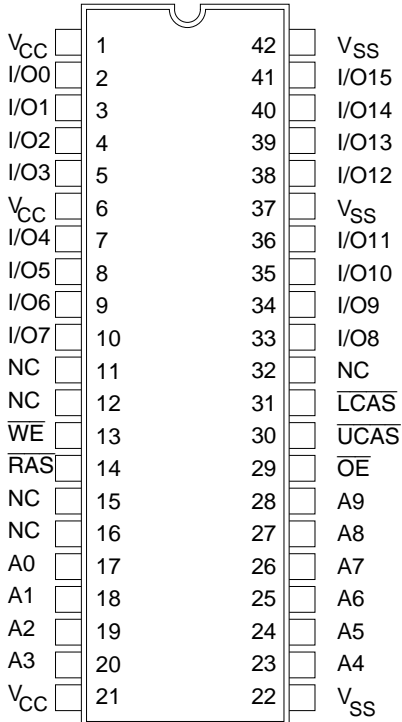

(Top view)

HM51W18165BTT/BLTT Series

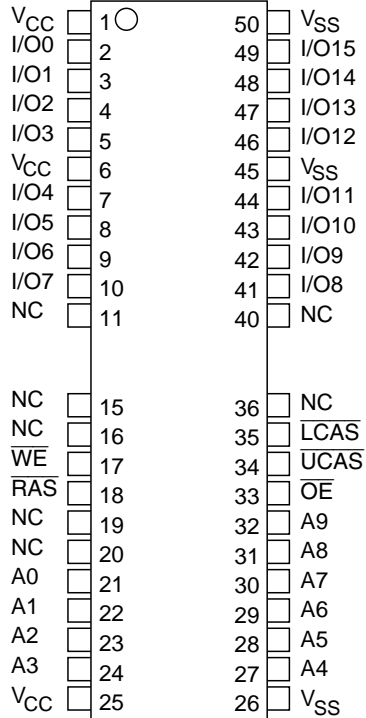

(Top view)

## Pin Description

Pin name	Function
A0 to A9	Address input — Row/Refresh address A0 to A9 — Column address A0 to A9
I/O0 to I/O15	Data input/Data output
RAS	Row address strobe
UCAS, LCAS	Column address strobe
WE	Read/Write enable
OE	Output enable
V <sub>CC</sub>	Power supply
V <sub>SS</sub>	Ground
NC	No connection



# HM51W16165B Series, HM51W18165B Series

## Truth Table

$\overline{\text{RAS}}$	$\overline{\text{LCAS}}$	$\overline{\text{UCAS}}$	$\overline{\text{WE}}$	$\overline{\text{OE}}$	Output	Operation
H	D	D	D	D	Open	Standby
L	L	H	H	L	Valid	Lower byte Read cycle
L	H	L	H	L	Valid	Upper byte
L	L	L	H	L	Valid	Word
L	L	H	L <sup>*2</sup>	D	Open	Lower byte Early write cycle
L	H	L	L <sup>*2</sup>	D	Open	Upper byte
L	L	L	L <sup>*2</sup>	D	Open	Word
L	L	H	L <sup>*2</sup>	H	Undefined	Lower byte Delayed write cycle
L	H	L	L <sup>*2</sup>	H	Undefined	Upper byte
L	L	L	L <sup>*2</sup>	H	Undefined	Word
L	L	H	H to L	L to H	Valid	Lower byte Read-modify-write cycle
L	H	L	H to L	L to H	Valid	Upper byte
L	L	L	H to L	L to H	Valid	Word
L	H	H	D	D	Open	Word $\overline{\text{RAS}}$ -only refresh cycle
H to L	H	L	D	D	Open	Word $\overline{\text{CAS}}$ -before- $\overline{\text{RAS}}$ refresh cycle or
H to L	L	H	D	D	Open	Word Self refresh cycle (L-version)
H to L	L	L	D	D	Open	Word
L	L	L	H	H	Open	Read cycle (Output disabled)

Notes: 1. H: High (inactive) L: Low (active) D: H or L

2.  $t_{\text{WCS}} \geq 0 \text{ ns}$  Early write cycle

$t_{\text{WCS}} < 0 \text{ ns}$  Delayed write cycle

3. Mode is determined by the OR function of the  $\overline{\text{UCAS}}$  and  $\overline{\text{LCAS}}$ . (Mode is set by the earliest of  $\overline{\text{UCAS}}$  and  $\overline{\text{LCAS}}$  active edge and reset by the latest of  $\overline{\text{UCAS}}$  and  $\overline{\text{LCAS}}$  inactive edge.) However write OPERATION and output HIZ control are done independently by each  $\overline{\text{UCAS}}$ ,  $\overline{\text{LCAS}}$ .

ex. if  $\overline{\text{RAS}} = \text{H to L}$ ,  $\overline{\text{UCAS}} = \text{H}$ ,  $\overline{\text{LCAS}} = \text{L}$ , then  $\overline{\text{CAS}}$ -before- $\overline{\text{RAS}}$  refresh cycle is selected.

# HM51W16165B Series, HM51W18165B Series

## Absolute Maximum Ratings

Parameter	Symbol	Value	Unit
Voltage on any pin relative to $V_{SS}$	$V_T$	$-0.5$ to $V_{CC} + 0.5$ ( $\leq 4.6$ V (max))	V
Supply voltage relative to $V_{SS}$	$V_{CC}$	$-0.5$ to $4.6$	V
Short circuit output current	$I_{out}$	50	mA
Power dissipation	$P_T$	1.0	W
Operating temperature	$T_{opr}$	0 to +70	°C
Storage temperature	$T_{stg}$	$-55$ to $+125$	°C

## Recommended DC Operating Conditions ( $T_a = 0$ to $+70^\circ\text{C}$ )

Parameter	Symbol	Min	Typ	Max	Unit	Notes
Supply voltage	$V_{CC}$	3.0	3.3	3.6	V	1, 2
Input high voltage	$V_{IH}$	2.0	—	$V_{CC} + 0.3$	V	1
Input low voltage	$V_{IL}$	$-0.3$	—	0.8	V	1

Notes: 1. All voltage referred to  $V_{SS}$ .

2. The supply voltage with all  $V_{CC}$  pins must be on the same level. The supply voltage with all  $V_{SS}$  pins must be on the same level.

# HM51W16165B Series, HM51W18165B Series

## DC Characteristics

( $T_a = 0$  to  $+70^\circ\text{C}$ ,  $V_{CC} = 3.3 \text{ V} \pm 0.3 \text{ V}$ ,  $V_{SS} = 0 \text{ V}$ ) (HM51W16165B Series)

		HM51W16165B							
		-6		-7		-8			
Parameter	Symbol	Min	Max	Min	Max	Min	Max	Unit	Test conditions
Operating current <sup>*1, *2</sup>	$I_{CC1}$	—	100	—	90	—	80	mA	$t_{RC} = \text{min}$
Standby current	$I_{CC2}$	—	2	—	2	—	2	mA	TTL interface $\overline{\text{RAS}}, \overline{\text{UCAS}}, \overline{\text{LCAS}} = V_{IH}$ Dout = High-Z
		—	1	—	1	—	1	mA	CMOS interface $\overline{\text{RAS}}, \overline{\text{UCAS}},$ $\overline{\text{LCAS}} \geq V_{CC} - 0.2 \text{ V}$ Dout = High-Z
Standby current (L-version)	$I_{CC2}$	—	150	—	150	—	150	$\mu\text{A}$	CMOS interface $\overline{\text{RAS}}, \overline{\text{UCAS}},$ $\overline{\text{LCAS}} \geq V_{CC} - 0.2 \text{ V}$ Dout = High-Z
$\overline{\text{RAS}}$ -only refresh current <sup>*2</sup>	$I_{CC3}$	—	100	—	90	—	80	mA	$t_{RC} = \text{min}$
Standby current <sup>*1</sup>	$I_{CC5}$	—	5	—	5	—	5	mA	$\overline{\text{RAS}} = V_{IH}$ $\overline{\text{UCAS}}, \overline{\text{LCAS}} = V_{IL}$ Dout = enable
$\overline{\text{CAS}}$ -before- $\overline{\text{RAS}}$ refresh current	$I_{CC6}$	—	100	—	90	—	80	mA	$t_{RC} = \text{min}$
EDO page mode current <sup>*1, *3</sup>	$I_{CC7}$	—	130	—	115	—	100	mA	$t_{HPC} = \text{min}$
Battery backup current <sup>*4</sup> (Standby with CBR refresh) (L-version)	$I_{CC10}$	—	400	—	400	—	400	$\mu\text{A}$	CMOS interface Dout = High-Z CBR refresh: $t_{RC} = 31.3 \mu\text{s}$ $t_{RAS} \leq 0.3 \mu\text{s}$
Self refresh mode current (L-version)	$I_{CC11}$	—	250	—	250	—	250	$\mu\text{A}$	CMOS interface $\overline{\text{RAS}}, \overline{\text{UCAS}},$ $\overline{\text{LCAS}} \leq 0.2 \text{ V}$ Dout = High-Z
Input leakage current	$I_{LI}$	-10	10	-10	10	-10	10	$\mu\text{A}$	$0 \text{ V} \leq V_{in} \leq 4.6 \text{ V}$
Output leakage current	$I_{LO}$	-10	10	-10	10	-10	10	$\mu\text{A}$	$0 \text{ V} \leq V_{out} \leq 4.6 \text{ V}$ Dout = disable
Output high voltage	$V_{OH}$	2.4	$V_{CC}$	2.4	$V_{CC}$	2.4	$V_{CC}$	V	High Iout = -2 mA
Output low voltage	$V_{OL}$	0	0.4	0	0.4	0	0.4	V	Low Iout = 2 mA

Notes: 1.  $I_{CC}$  depends on output load condition when the device is selected.  $I_{CC}$  max is specified at the output open condition.

2. Address can be changed once or less while  $\overline{\text{RAS}} = V_{IL}$ .

3. Address can be changed once or less while  $\overline{\text{UCAS}}$  and  $\overline{\text{LCAS}} = V_{IH}$ .

4.  $V_{IH} \geq V_{CC} - 0.2 \text{ V}$ ,  $0 \text{ V} \leq V_{IL} \leq 0.2 \text{ V}$ .



# HM51W16165B Series, HM51W18165B Series

## DC Characteristics

( $T_a = 0$  to  $+70^\circ\text{C}$ ,  $V_{CC} = 3.3 \text{ V} \pm 0.3 \text{ V}$ ,  $V_{SS} = 0 \text{ V}$ ) (HM51W18165B Series)

### HM51W18165B

Parameter	Symbol	-6		-7		-8		Unit	Test conditions
		Min	Max	Min	Max	Min	Max		
Operating current <sup>*1, *2</sup>	$I_{CC1}$	—	170	—	150	—	130	mA	$t_{RC} = \text{min}$
Standby current	$I_{CC2}$	—	2	—	2	—	2	mA	TTL interface $\overline{\text{RAS}}, \overline{\text{UCAS}}, \overline{\text{LCAS}} = V_{IH}$ Dout = High-Z
		—	1	—	1	—	1	mA	CMOS interface $\overline{\text{RAS}}, \overline{\text{UCAS}},$ $\overline{\text{LCAS}} \geq V_{CC} - 0.2 \text{ V}$ Dout = High-Z
Standby current (L-version)	$I_{CC2}$	—	150	—	150	—	150	$\mu\text{A}$	CMOS interface $\overline{\text{RAS}}, \overline{\text{UCAS}},$ $\overline{\text{LCAS}} \geq V_{CC} - 0.2 \text{ V}$ Dout = High-Z
$\overline{\text{RAS}}$ -only refresh current <sup>*2</sup>	$I_{CC3}$	—	170	—	150	—	130	mA	$t_{RC} = \text{min}$
Standby current <sup>*1</sup>	$I_{CC5}$	—	5	—	5	—	5	mA	$\overline{\text{RAS}} = V_{IH}$ $\overline{\text{UCAS}}, \overline{\text{LCAS}} = V_{IL}$ Dout = enable
$\overline{\text{CAS}}$ -before- $\overline{\text{RAS}}$ refresh current	$I_{CC6}$	—	170	—	150	—	130	mA	$t_{RC} = \text{min}$
EDO page mode current <sup>*1, *3</sup>	$I_{CC7}$	—	185	—	165	—	150	mA	$t_{HPC} = \text{min}$
Battery backup current <sup>*4</sup> (Standby with CBR refresh) (L-version)	$I_{CC10}$	—	400	—	400	—	400	$\mu\text{A}$	CMOS interface Dout = High-Z CBR refresh: $t_{RC} = 125 \mu\text{s}$ $t_{RAS} \leq 0.3 \mu\text{s}$
Self refresh mode current (L-version)	$I_{CC11}$	—	250	—	250	—	250	$\mu\text{A}$	CMOS interface $\overline{\text{RAS}}, \overline{\text{UCAS}},$ $\overline{\text{LCAS}} \leq 0.2 \text{ V}$ Dout = High-Z
Input leakage current	$I_{LI}$	-10	10	-10	10	-10	10	$\mu\text{A}$	$0 \text{ V} \leq V_{in} \leq 4.6 \text{ V}$
Output leakage current	$I_{LO}$	-10	10	-10	10	-10	10	$\mu\text{A}$	$0 \text{ V} \leq V_{out} \leq 4.6 \text{ V}$ Dout = disable
Output high voltage	$V_{OH}$	2.4	$V_{CC}$	2.4	$V_{CC}$	2.4	$V_{CC}$	V	High Iout = -2 mA
Output low voltage	$V_{OL}$	0	0.4	0	0.4	0	0.4	V	Low Iout = 2 mA

Notes: 1.  $I_{CC}$  depends on output load condition when the device is selected.  $I_{CC}$  max is specified at the output open condition.

2. Address can be changed once or less while  $\overline{\text{RAS}} = V_{IL}$ .

3. Address can be changed once or less while  $\overline{\text{UCAS}}$  and  $\overline{\text{LCAS}} = V_{IH}$ .

4.  $V_{IH} \geq V_{CC} - 0.2 \text{ V}$ ,  $0 \text{ V} \leq V_{IL} \leq 0.2 \text{ V}$ .

## HM51W16165B Series, HM51W18165B Series

Capacitance ( $T_a = 25^\circ\text{C}$ ,  $V_{CC} = 3.3\text{ V} \pm 0.3\text{ V}$ )

Parameter	Symbol	Typ	Max	Unit	Notes
Input capacitance (Address)	$C_{i1}$	—	5	pF	1
Input capacitance (Clocks)	$C_{i2}$	—	7	pF	1
Output capacitance (Data-in, Data-out)	$C_{i/O}$	—	7	pF	1, 2

Notes : 1. Capacitance measured with Boonton Meter or effective capacitance measuring method.

2.  $\overline{\text{RAS}}$ ,  $\overline{\text{UCAS}}$  and  $\overline{\text{LCAS}} = V_{IH}$  to disable Dout.

# HM51W16165B Series, HM51W18165B Series

**AC Characteristics** ( $T_a = 0$  to  $+70^\circ\text{C}$ ,  $V_{CC} = 3.3\text{ V} \pm 0.3\text{ V}$ ,  $V_{SS} = 0\text{ V}$ )\*1, \*2, \*18, \*19, \*20

## Test Conditions

- Input rise and fall time: 2 ns
- Input levels: 0 V, 3.0 V
- Input timing reference levels: 0.8 V, 2.0 V
- Output timing reference levels: 0.8 V, 2.0 V
- Output load: 1 TTL gate +  $C_L$  (100 pF) (Including scope and jig)

**Read, Write, Read-Modify-Write and Refresh Cycles** (Common parameters)

		<b>HM51W16165B/HM51W18165B</b>							
		<b>-6</b>		<b>-7</b>		<b>-8</b>			
<b>Parameter</b>	<b>Symbol</b>	<b>Min</b>	<b>Max</b>	<b>Min</b>	<b>Max</b>	<b>Min</b>	<b>Max</b>	<b>Unit</b>	<b>Notes</b>
Random read or write cycle time	$t_{RC}$	104	—	124	—	144	—	ns	
$\overline{\text{RAS}}$ precharge time	$t_{RP}$	40	—	50	—	60	—	ns	
$\overline{\text{CAS}}$ precharge time	$t_{CP}$	10	—	13	—	15	—	ns	
$\overline{\text{RAS}}$ pulse width	$t_{RAS}$	60	10000	70	10000	80	10000	ns	
$\overline{\text{CAS}}$ pulse width	$t_{CAS}$	10	10000	13	10000	15	10000	ns	
Row address setup time	$t_{ASR}$	0	—	0	—	0	—	ns	
Row address hold time	$t_{RAH}$	10	—	10	—	10	—	ns	
Column address setup time	$t_{ASC}$	0	—	0	—	0	—	ns	21
Column address hold time	$t_{CAH}$	10	—	13	—	15	—	ns	21
$\overline{\text{RAS}}$ to $\overline{\text{CAS}}$ delay time	$t_{RCD}$	20	45	20	52	20	60	ns	3
$\overline{\text{RAS}}$ to column address delay time	$t_{RAD}$	15	30	15	35	15	40	ns	4
$\overline{\text{RAS}}$ hold time	$t_{RSH}$	15	—	18	—	20	—	ns	
$\overline{\text{CAS}}$ hold time	$t_{CSH}$	48	—	58	—	68	—	ns	23
$\overline{\text{CAS}}$ to $\overline{\text{RAS}}$ precharge time	$t_{CRP}$	5	—	5	—	5	—	ns	22
$\overline{\text{OE}}$ to Din delay time	$t_{OED}$	15	—	18	—	20	—	ns	5
$\overline{\text{OE}}$ delay time from Din	$t_{DZO}$	0	—	0	—	0	—	ns	6
$\overline{\text{CAS}}$ delay time from Din	$t_{DZC}$	0	—	0	—	0	—	ns	6
Transition time (rise and fall)	$t_T$	2	50	2	50	2	50	ns	7

# HM51W16165B Series, HM51W18165B Series

## Read Cycle

Parameter	Symbol	HM51W16165B/HM51W18165B						Unit	Notes
		-6		-7		-8			
		Min	Max	Min	Max	Min	Max		
Access time from $\overline{\text{RAS}}$	$t_{\text{RAC}}$	—	60	—	70	—	80	ns	8, 9
Access time from $\overline{\text{CAS}}$	$t_{\text{CAC}}$	—	15	—	18	—	20	ns	9, 10, 17
Access time from address	$t_{\text{AA}}$	—	30	—	35	—	40	ns	9, 11, 17
Access time from $\overline{\text{OE}}$	$t_{\text{OEA}}$	—	15	—	18	—	20	ns	9
Read command setup time	$t_{\text{RCS}}$	0	—	0	—	0	—	ns	21
Read command hold time to $\overline{\text{CAS}}$	$t_{\text{RCH}}$	0	—	0	—	0	—	ns	12, 22
Read command hold time from $\overline{\text{RAS}}$	$t_{\text{RCHR}}$	60	—	70	—	80	—	ns	
Read command hold time to $\overline{\text{RAS}}$	$t_{\text{RRH}}$	5	—	5	—	5	—	ns	12
Column address to $\overline{\text{RAS}}$ lead time	$t_{\text{RAL}}$	30	—	35	—	40	—	ns	
Column address to $\overline{\text{CAS}}$ lead time	$t_{\text{CAL}}$	18	—	23	—	28	—	ns	
$\overline{\text{CAS}}$ to output in low-Z	$t_{\text{CLZ}}$	0	—	0	—	0	—	ns	
Output data hold time	$t_{\text{OH}}$	3	—	3	—	3	—	ns	27
Output data hold time from $\overline{\text{OE}}$	$t_{\text{OHO}}$	3	—	3	—	3	—	ns	
Output buffer turn-off time	$t_{\text{OFF}}$	—	15	—	15	—	15	ns	13, 27
Output buffer turn-off to $\overline{\text{OE}}$	$t_{\text{OEZ}}$	—	15	—	15	—	15	ns	13
$\overline{\text{CAS}}$ to Din delay time	$t_{\text{CDD}}$	15	—	18	—	20	—	ns	5
Output data hold time from $\overline{\text{RAS}}$	$t_{\text{OHR}}$	3	—	3	—	3	—	ns	27
Output buffer turn-off to $\overline{\text{RAS}}$	$t_{\text{OFR}}$	—	15	—	15	—	15	ns	27
Output buffer turn-off to $\overline{\text{WE}}$	$t_{\text{WEZ}}$	—	15	—	15	—	15	ns	
$\overline{\text{WE}}$ to Din delay time	$t_{\text{WED}}$	15	—	18	—	20	—	ns	
$\overline{\text{RAS}}$ to Din delay time	$t_{\text{RDD}}$	15	—	18	—	20	—	ns	

# HM51W16165B Series, HM51W18165B Series

## Write Cycle

		HM51W16165B/HM51W18165B							
		-6		-7		-8			
Parameter	Symbol	Min	Max	Min	Max	Min	Max	Unit	Notes
Write command setup time	$t_{WCS}$	0	—	0	—	0	—	ns	14, 21
Write command hold time	$t_{WCH}$	10	—	13	—	15	—	ns	21
Write command pulse width	$t_{WP}$	10	—	10	—	10	—	ns	
Write command to $\overline{RAS}$ lead time	$t_{RWL}$	10	—	13	—	15	—	ns	
Write command to $\overline{CAS}$ lead time	$t_{CWL}$	10	—	13	—	15	—	ns	23
Data-in setup time	$t_{DS}$	0	—	0	—	0	—	ns	15, 23
Data-in hold time	$t_{DH}$	10	—	13	—	15	—	ns	15, 23

## Read-Modify-Write Cycle

		HM51W16165B/HM51W18165B							
		-6		-7		-8			
Parameter	Symbol	Min	Max	Min	Max	Min	Max	Unit	Notes
Read-modify-write cycle time	$t_{RWC}$	136	—	161	—	185	—	ns	
$RAS$ to $\overline{WE}$ delay time	$t_{RWD}$	79	—	92	—	104	—	ns	14
$CAS$ to $\overline{WE}$ delay time	$t_{CWD}$	34	—	40	—	44	—	ns	14
Column address to $\overline{WE}$ delay time	$t_{AWD}$	49	—	57	—	64	—	ns	14
$\overline{OE}$ hold time from $\overline{WE}$	$t_{OEH}$	15	—	18	—	20	—	ns	

## Refresh Cycle

		HM51W16165B/HM51W18165B							
		-6		-7		-8			
Parameter	Symbol	Min	Max	Min	Max	Min	Max	Unit	Notes
$CAS$ setup time (CBR refresh cycle)	$t_{CSR}$	5	—	5	—	5	—	ns	21
$CAS$ hold time (CBR refresh cycle)	$t_{CHR}$	10	—	10	—	10	—	ns	22
$\overline{RAS}$ precharge to $\overline{CAS}$ hold time	$t_{RPC}$	0	—	0	—	0	—	ns	21

# HM51W16165B Series, HM51W18165B Series

## EDO Page Mode Cycle

Parameter	Symbol	HM51W16165B/HM51W18165B						Unit	Notes
		-6		-7		-8			
		Min	Max	Min	Max	Min	Max		
EDO page mode cycle time	$t_{HPC}$	25	—	30	—	35	—	ns	25
EDO page mode $\overline{RAS}$ pulse width	$t_{RASP}$	—	100000	—	100000	—	100000	ns	16
Access time from $\overline{CAS}$ precharge	$t_{CPA}$	—	35	—	40	—	45	ns	9, 17
$\overline{RAS}$ hold time from $\overline{CAS}$ precharge	$t_{CPRH}$	35	—	40	—	45	—	ns	
Output data hold time from $\overline{CAS}$ low	$t_{DOH}$	3	—	3	—	3	—	ns	9, 17
$\overline{CAS}$ hold time referred $\overline{OE}$	$t_{COL}$	10	—	13	—	15	—	ns	
$\overline{CAS}$ to $\overline{OE}$ setup time	$t_{COP}$	5	—	5	—	5	—	ns	
Read command hold time from $\overline{CAS}$ precharge	$t_{RCHC}$	35	—	40	—	45	—	ns	

## EDO Page Mode Read-Modify-Write Cycle

Parameter	Symbol	HM51W16165B/HM51W18165B						Unit	Notes
		-6		-7		-8			
		Min	Max	Min	Max	Min	Max		
EDO page mode read-modify-write cycle time	$t_{HPRWC}$	68	—	79	—	88	—	ns	
$\overline{WE}$ delay time from $\overline{CAS}$ precharge	$t_{CPW}$	54	—	62	—	69	—	ns	14

## Refresh (HM51W16165B Series)

Parameter	Symbol	Max	Unit	Note
Refresh period	$t_{REF}$	64	ms	4096 cycles
Refresh period (L-version)	$t_{REF}$	128	ms	4096 cycles

## Refresh (HM51W18165B Series)

Parameter	Symbol	Max	Unit	Note
Refresh period	$t_{REF}$	16	ms	1024 cycles
Refresh period (L-version)	$t_{REF}$	128	ms	1024 cycles



# HM51W16165B Series, HM51W18165B Series

## Self Refresh Mode (L-version)

Parameter	Symbol	HM51W16165BL/HM51W18165BL						Unit	Notes
		-6		-7		-8			
		Min	Max	Min	Max	Min	Max		
RAS pulse width (self refresh)	$t_{RASS}$	100	—	100	—	100	—	$\mu\text{s}$	
RAS precharge time (self refresh)	$t_{RPS}$	110	—	130	—	150	—	ns	
CAS hold time (self refresh)	$t_{CHS}$	-50	—	-50	—	-50	—	ns	

- Notes:
1. AC measurements assume  $t_T = 2$  ns.
  2. An initial pause of 200  $\mu\text{s}$  is required after power up followed by a minimum of eight initialization cycles (any combination of cycles containing  $\overline{\text{RAS}}$ -only refresh or  $\overline{\text{CAS}}$ -before- $\overline{\text{RAS}}$  refresh).
  3. Operation with the  $t_{RCD}$  (max) limit insures that  $t_{RAC}$  (max) can be met,  $t_{RCD}$  (max) is specified as a reference point only; if  $t_{RCD} \geq t_{RAD}$  (max) +  $t_{AA}$  (max) -  $t_{CAC}$  (max), then access time is controlled exclusively by  $t_{CAC}$ .
  4. Operation with the  $t_{RAD}$  (max) limit insures that  $t_{RAC}$  (max) can be met,  $t_{RAD}$  (max) is specified as a reference point only; if  $t_{RAD}$  is greater than the specified  $t_{RAD}$  (max) limit, then access time is controlled exclusively by  $t_{AA}$ .
  5. Either  $t_{OED}$  or  $t_{CDD}$  must be satisfied.
  6. Either  $t_{DZO}$  or  $t_{DZC}$  must be satisfied.
  7.  $V_{IH}$  (min) and  $V_{IL}$  (max) are reference levels for measuring timing of input signals. Also, transition times are measured between  $V_{IH}$  (min) and  $V_{IL}$  (max).
  8. Assumes that  $t_{RCD} \leq t_{RCD}$  (max) and  $t_{RAD} \leq t_{RAD}$  (max). If  $t_{RCD}$  or  $t_{RAD}$  is greater than the maximum recommended value shown in this table,  $t_{RAC}$  exceeds the value shown.
  9. Measured with a load circuit equivalent to 1 TTL loads and 100 pF.
  10. Assumes that  $t_{RCD} \geq t_{RCD}$  (max) and  $t_{RCD} + t_{CAC}$  (max)  $\geq t_{RAD} + t_{AA}$  (max).
  11. Assumes that  $t_{RAD} \geq t_{RAD}$  (max) and  $t_{RCD} + t_{CAC}$  (max)  $\leq t_{RAD} + t_{AA}$  (max).
  12. Either  $t_{RCH}$  or  $t_{RRH}$  must be satisfied for a read cycles.
  13.  $t_{OFF}$  (max) and  $t_{OEZ}$  (max) define the time at which the outputs achieve the open circuit condition and are not referred to output voltage levels.
  14.  $t_{WCS}$ ,  $t_{RWD}$ ,  $t_{CWD}$ ,  $t_{AWD}$  and  $t_{CPW}$  are not restrictive operating parameters. They are included in the data sheet as electrical characteristics only; if  $t_{WCS} \geq t_{WCS}$  (min), the cycle is an early write cycle and the data out pin will remain open circuit (high impedance) throughout the entire cycle; if  $t_{RWD} \geq t_{RWD}$  (min),  $t_{CWD} \geq t_{CWD}$  (min), and  $t_{AWD} \geq t_{AWD}$  (min), or  $t_{CWD} \geq t_{CWD}$  (min),  $t_{AWD} \geq t_{AWD}$  (min) and  $t_{CPW} \geq t_{CPW}$  (min), the cycle is a read-modify-write and the data output will contain data read from the selected cell; if neither of the above sets of conditions is satisfied, the condition of the data out (at access time) is indeterminate.
  15. These parameters are referred to  $\overline{\text{UCAS}}$  and  $\overline{\text{LCAS}}$  leading edge in early write cycles and to  $\overline{\text{WE}}$  leading edge in delayed write or read-modify-write cycles.
  16.  $t_{RASP}$  defines  $\overline{\text{RAS}}$  pulse width in EDO page mode cycles.
  17. Access time is determined by the longest among  $t_{AA}$ ,  $t_{CAC}$  and  $t_{CPA}$ .
  18. In delayed write or read-modify-write cycles,  $\overline{\text{OE}}$  must disable output buffer prior to applying data to the device. After  $\overline{\text{RAS}}$  is reset, if  $t_{OEH} \geq t_{CWL}$ , the I/O pin will remain open circuit (high impedance); if  $t_{OEH} < t_{CWL}$ , invalid data will be out at each I/O.
  19. When both  $\overline{\text{UCAS}}$  and  $\overline{\text{LCAS}}$  go low at the same time, all 16-bit data are written into the device.  $\overline{\text{UCAS}}$  and  $\overline{\text{LCAS}}$  cannot be staggered within the same write/read cycles.
  20. All the  $V_{CC}$  and  $V_{SS}$  pins shall be supplied with the same voltages.

## HM51W16165B Series, HM51W18165B Series

21.  $t_{ASC}$ ,  $t_{CAH}$ ,  $t_{RCS}$ ,  $t_{WCS}$ ,  $t_{WCH}$ ,  $t_{CSR}$  and  $t_{RPC}$  are determined by the earlier falling edge of  $\overline{UCAS}$  or  $\overline{LCAS}$ .
22.  $t_{CRP}$ ,  $t_{CHR}$ ,  $t_{RCH}$ ,  $t_{CPA}$  and  $t_{CPW}$  are determined by the later rising edge of  $\overline{UCAS}$  or  $\overline{LCAS}$ .
23.  $t_{CWL}$ ,  $t_{DH}$ ,  $t_{DS}$  and  $t_{CHS}$  should be satisfied by both  $\overline{UCAS}$  and  $\overline{LCAS}$ .
24.  $t_{CP}$  is determined by the time that both  $\overline{UCAS}$  and  $\overline{LCAS}$  are high.
25.  $t_{HPC}$  (min) can be achieved during a series of EDO page mode write cycles or EDO page mode read cycles. If both write and read operation are mixed in a EDO page mode  $\overline{RAS}$  cycle (EDO page mode mix cycle (1), (2)), minimum value of  $\overline{CAS}$  cycle ( $t_{CAS} + t_{CP} + 2 t_T$ ) becomes greater than the specified  $t_{HPC}$  (min) value. The value of  $\overline{CAS}$  cycle time of mixed EDO page mode is shown in EDO page mode mix cycle (1) and (2).
26. When output buffers are enabled once, sustain the low impedance state until valid data is obtained. When output buffer is turned on and off within a very short time, generally it causes large  $V_{CC}/V_{SS}$  line noise, which causes to degrade  $V_{IH\ min}/V_{IL\ max}$  level.
27. Data output turns off and becomes high impedance from later rising edge of  $\overline{RAS}$  and  $\overline{CAS}$ . Hold time and turn off time are specified by the timing specifications of later rising edge of  $\overline{RAS}$  and  $\overline{CAS}$  between  $t_{OHR}$  and  $t_{OH}$ , and between  $t_{OFR}$  and  $t_{OFF}$ .
28. Please do not use  $t_{RASS}$  timing,  $10\ \mu s \leq t_{RASS} \leq 100\ \mu s$ . During this period, the device is in transition state from normal operation mode to self refresh mode. If  $t_{RASS} \geq 100\ \mu s$ , then  $\overline{RAS}$  precharge time should use  $t_{RPS}$  instead of  $t_{RP}$ .
29. If you use distributed CBR refresh mode with  $15.6\ \mu s$  interval in normal read/write cycle, CBR refresh should be executed within  $15.6\ \mu s$  immediately after exiting from and before entering into self refresh mode.
30. If you use  $\overline{RAS}$  only refresh or CBR burst refresh mode in normal read/write cycle, 4096 or 1024 cycles (4096 cycles: HM51W16165B Series, 1024 cycles: HM51W18165B Series) of distributed CBR refresh with  $15.6\ \mu s$  interval should be executed within 64 or 16 ms (64 ms: HM51W16165B, 16 ms: HM51W18165B) immediately after exiting from and before entering into the self refresh mode.
31. Repetitive self refresh mode without refreshing all memory is not allowed. Once you exit from self refresh mode, all memory cells need to be refreshed before re-entering the self refresh mode again.
32.  H or L (H:  $V_{IH\ (min)} \leq V_{IN} \leq V_{IH\ (max)}$ , L:  $V_{IL\ (min)} \leq V_{IN} \leq V_{IL\ (max)}$ )  
 Invalid Dout



**Notes concerning  $\overline{2CAS}$  control**

Please do not separate the  $\overline{UCAS/LCAS}$  operation timing intentionally. However skew between  $\overline{UCAS/LCAS}$  are allowed under the following conditions.

1. Each of the  $\overline{UCAS/LCAS}$  should satisfy the timing specifications individually.
2. Different operation mode for upper/lower byte is not allowed; such as following.

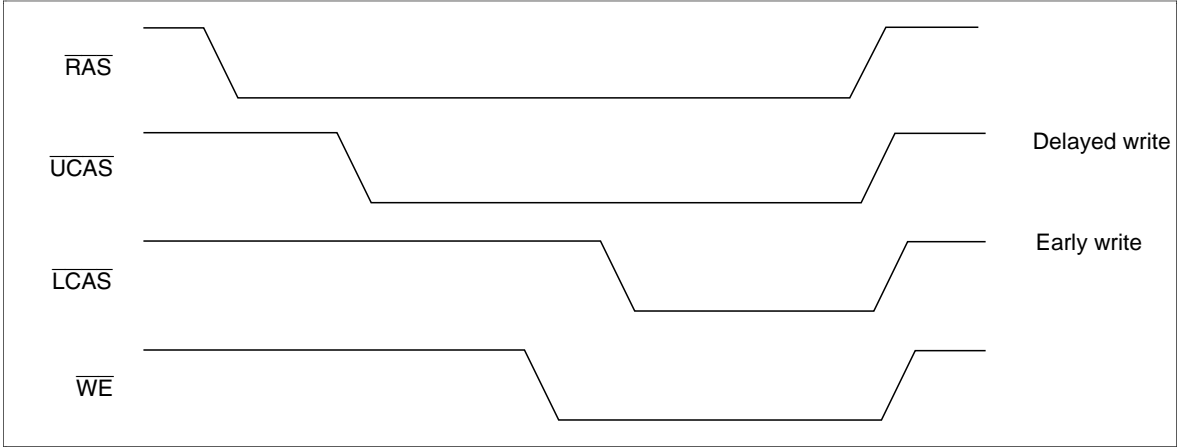

3. Closely separated upper/lower byte control is not allowed. However when the condition ( $t_{CP} \leq t_{UL}$ ) is satisfied, EDO page mode can be performed.

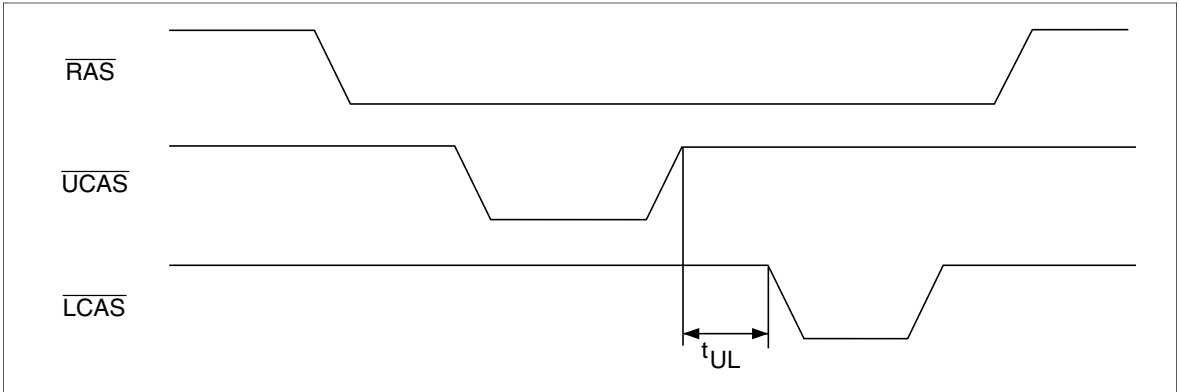

4. Byte control operation by remaining  $\overline{UCAS}$  or  $\overline{LCAS}$  high is guaranteed.

# HM51W16165B Series, HM51W18165B Series

## Timing Waveforms\*32

### Read Cycle

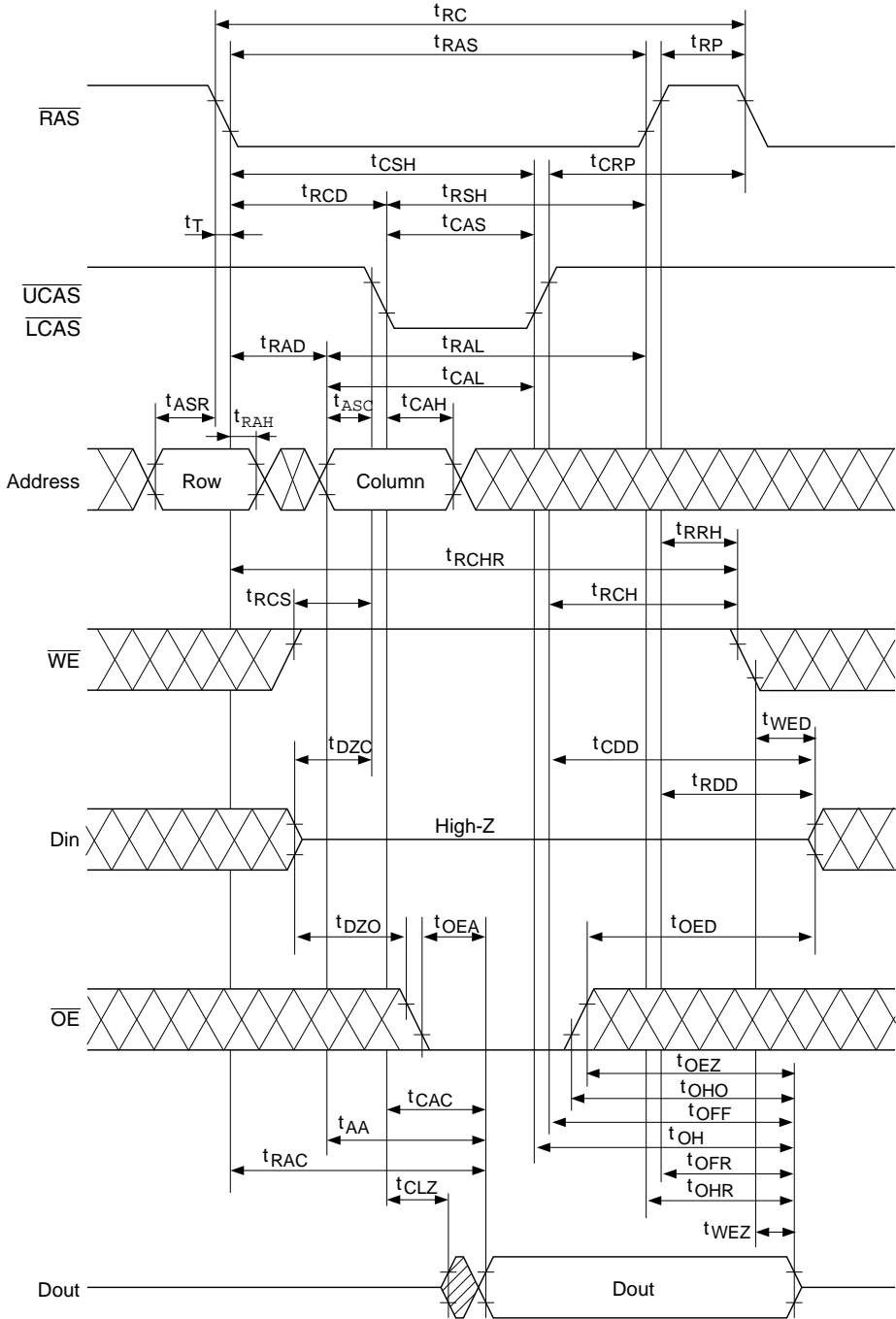

## Early Write Cycle

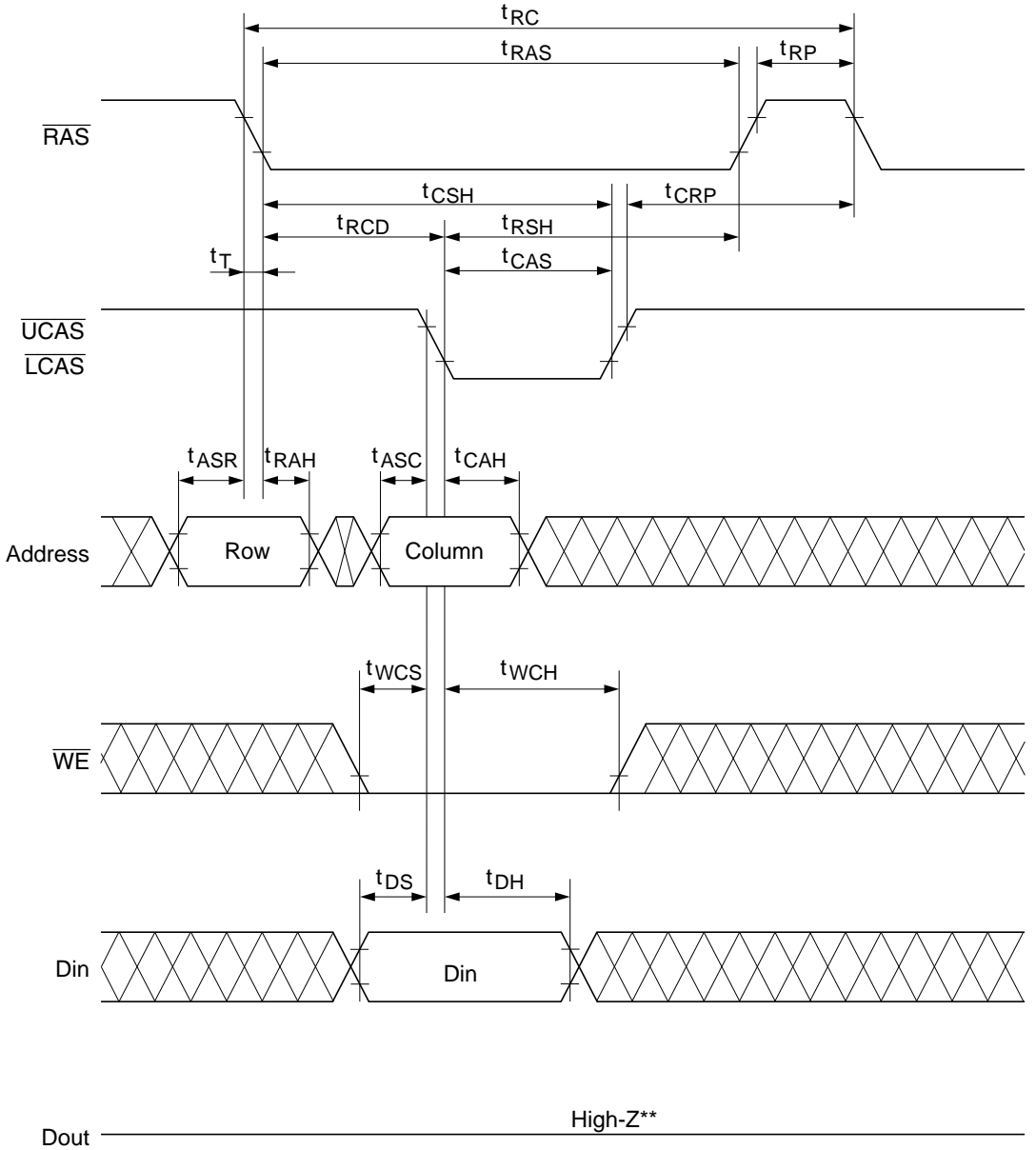

\*  $\overline{OE}$  : H or L

\*\*  $t_{WCS} \geq t_{WCS}(\text{min})$

# HM51W16165B Series, HM51W18165B Series

## Delayed Write Cycle\*18

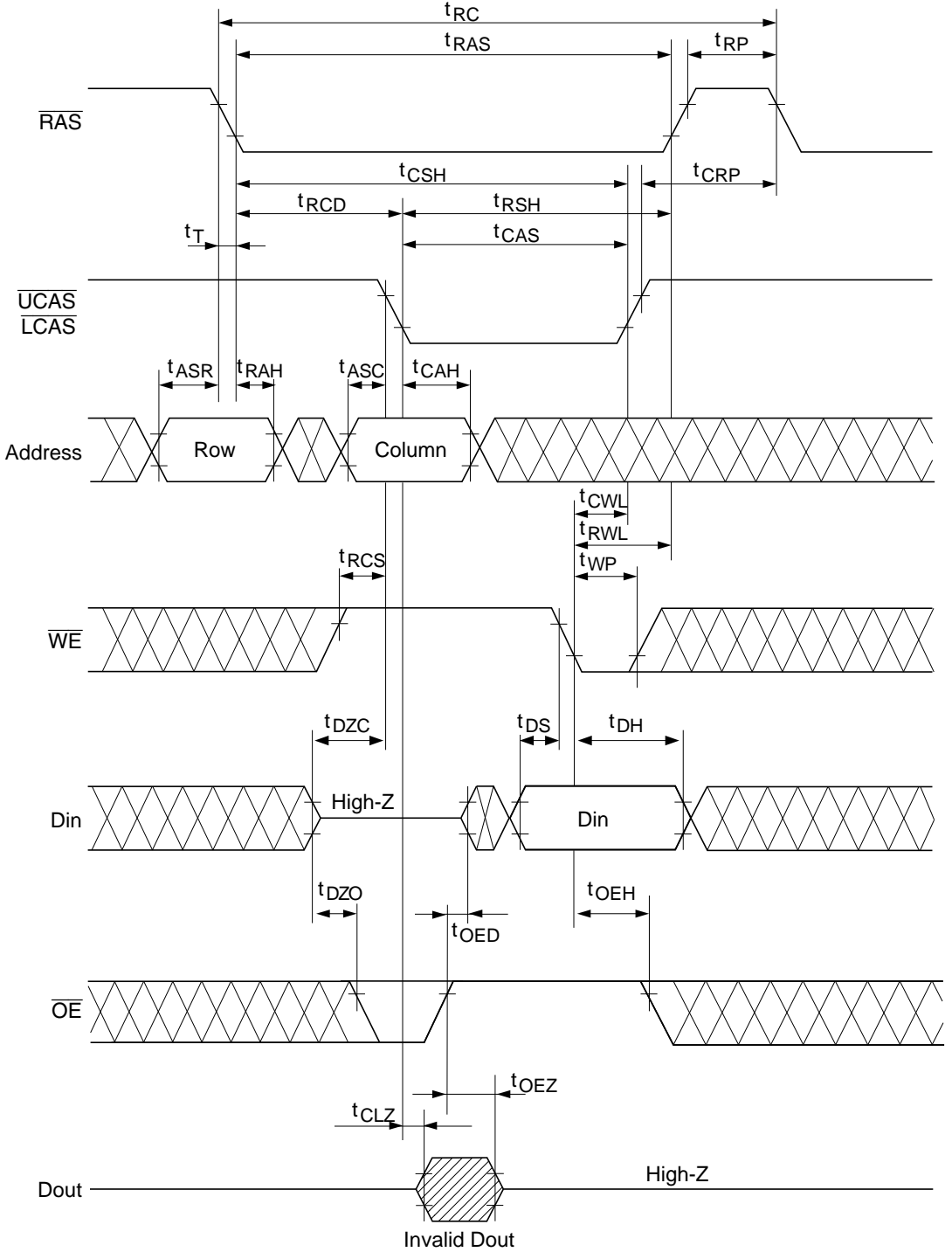

## Read-Modify-Write Cycle\*18

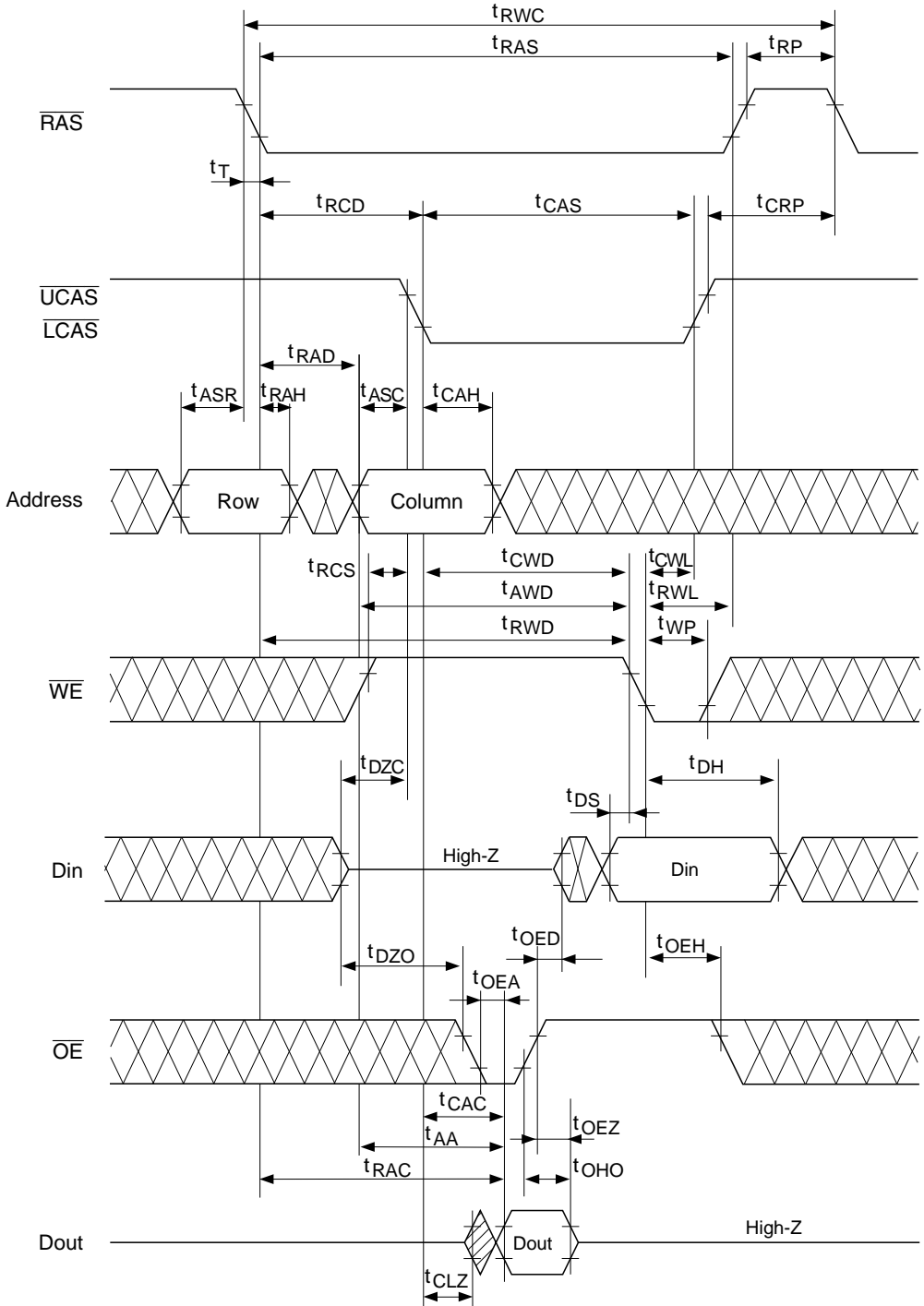

# HM51W16165B Series, HM51W18165B Series

## RAS-Only Refresh Cycle

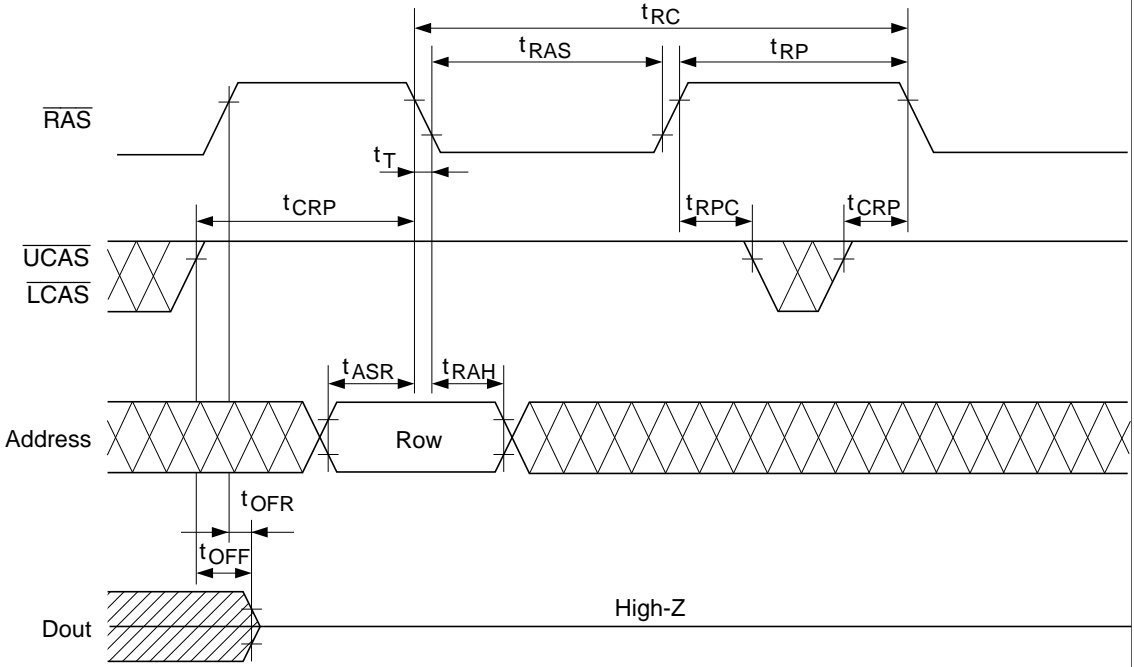

\*  $\overline{OE}$ ,  $\overline{WE}$ : H or L

CAS-Before-RAS Refresh Cycle

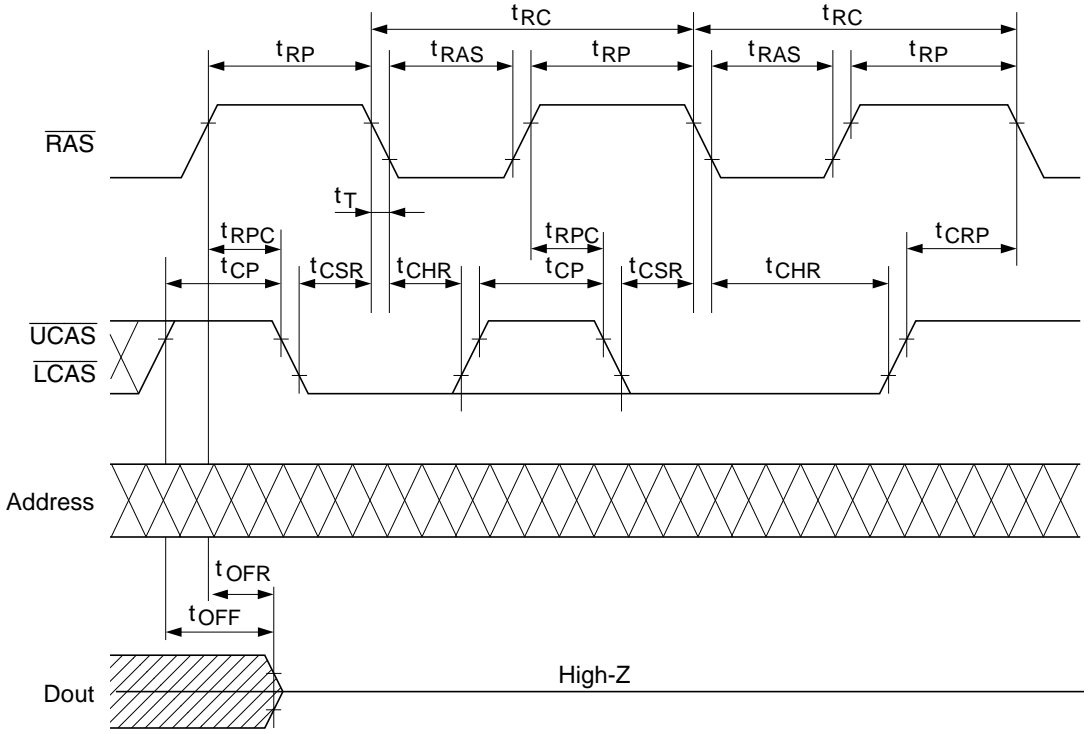

\*  $\overline{OE}$ ,  $\overline{WE}$  : H or L

# HM51W16165B Series, HM51W18165B Series

## Hidden Refresh Cycle

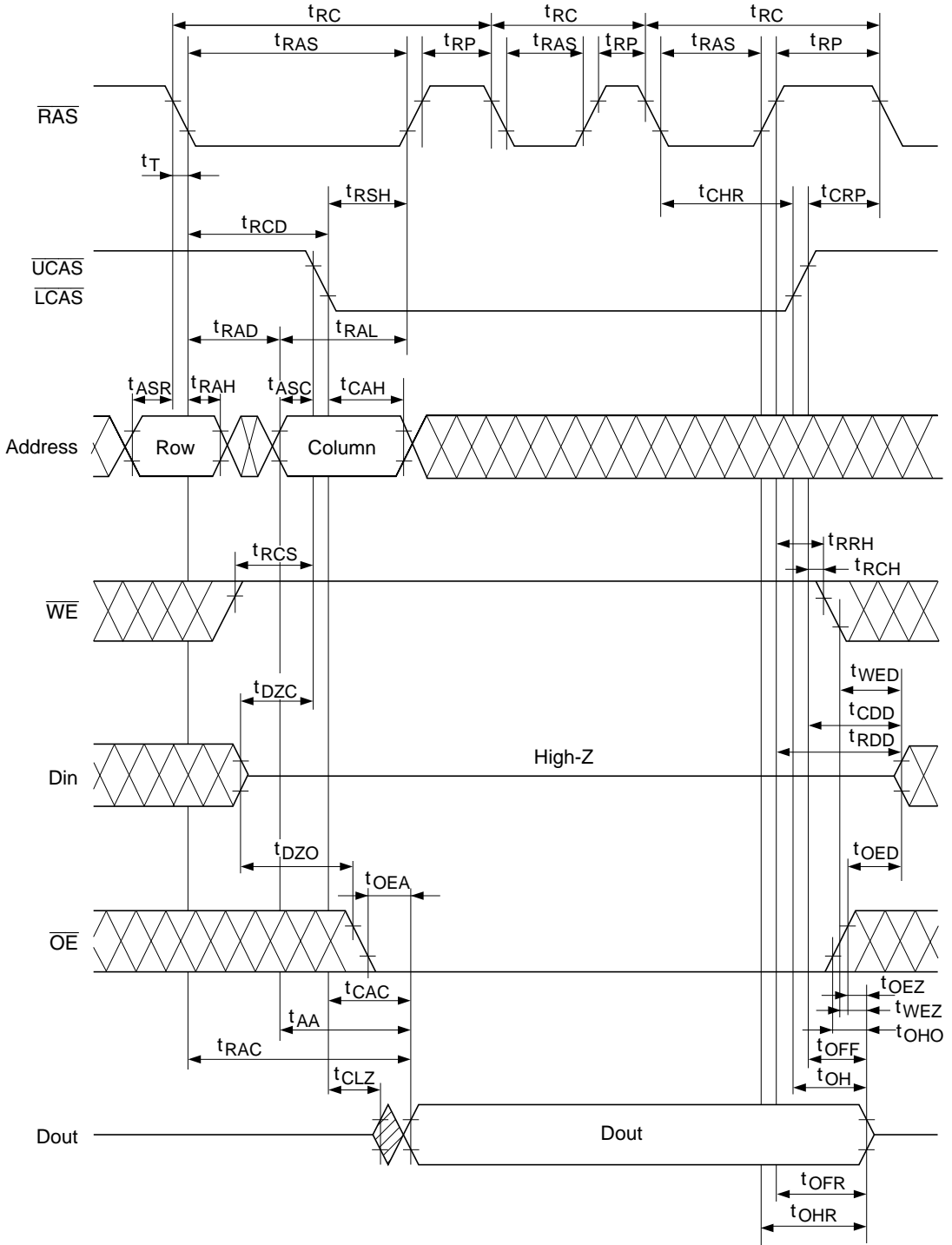



## EDO Page Mode Read Cycle

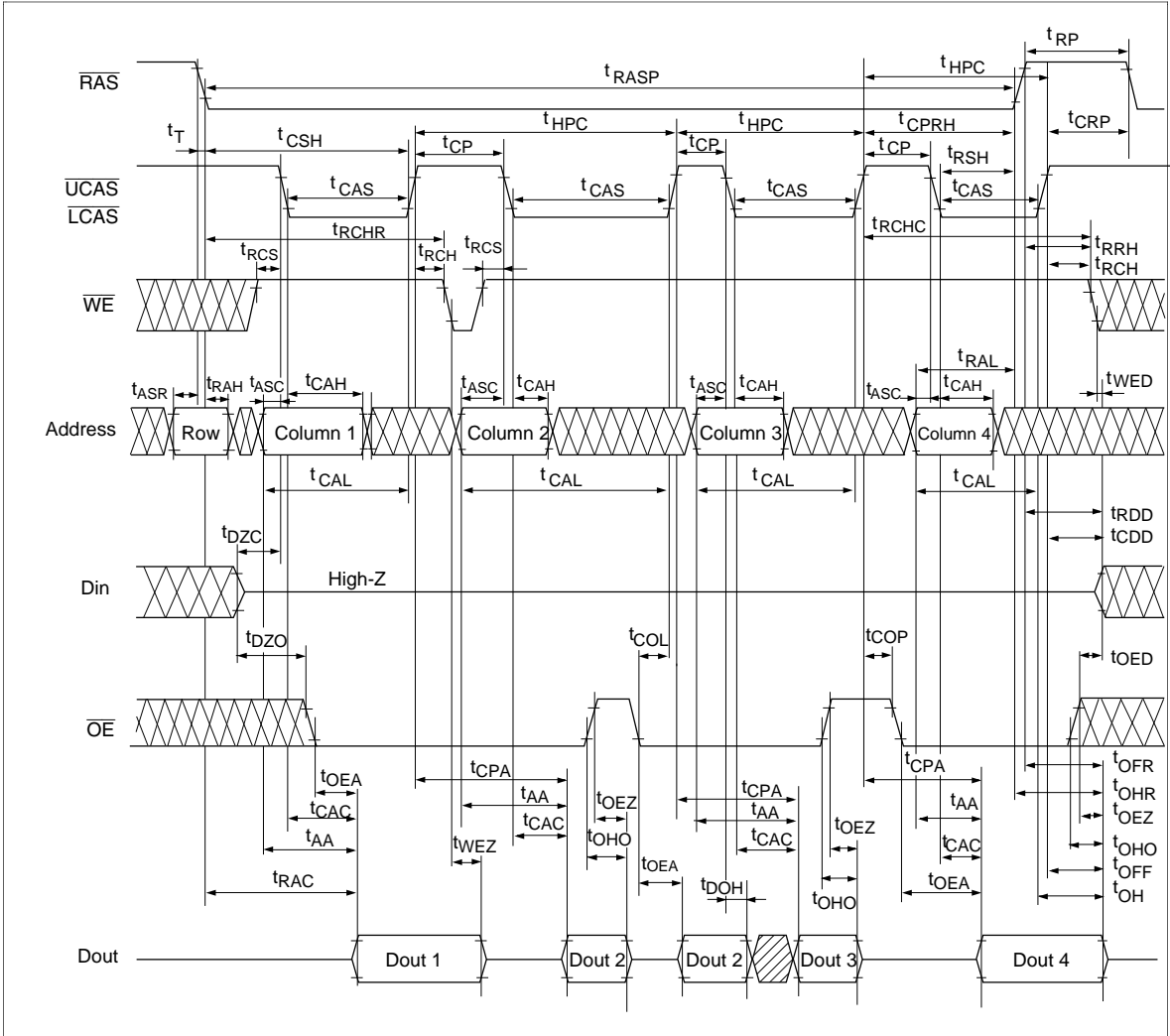

# HM51W16165B Series, HM51W18165B Series

## EDO Page Mode Read Cycle (2CAS)

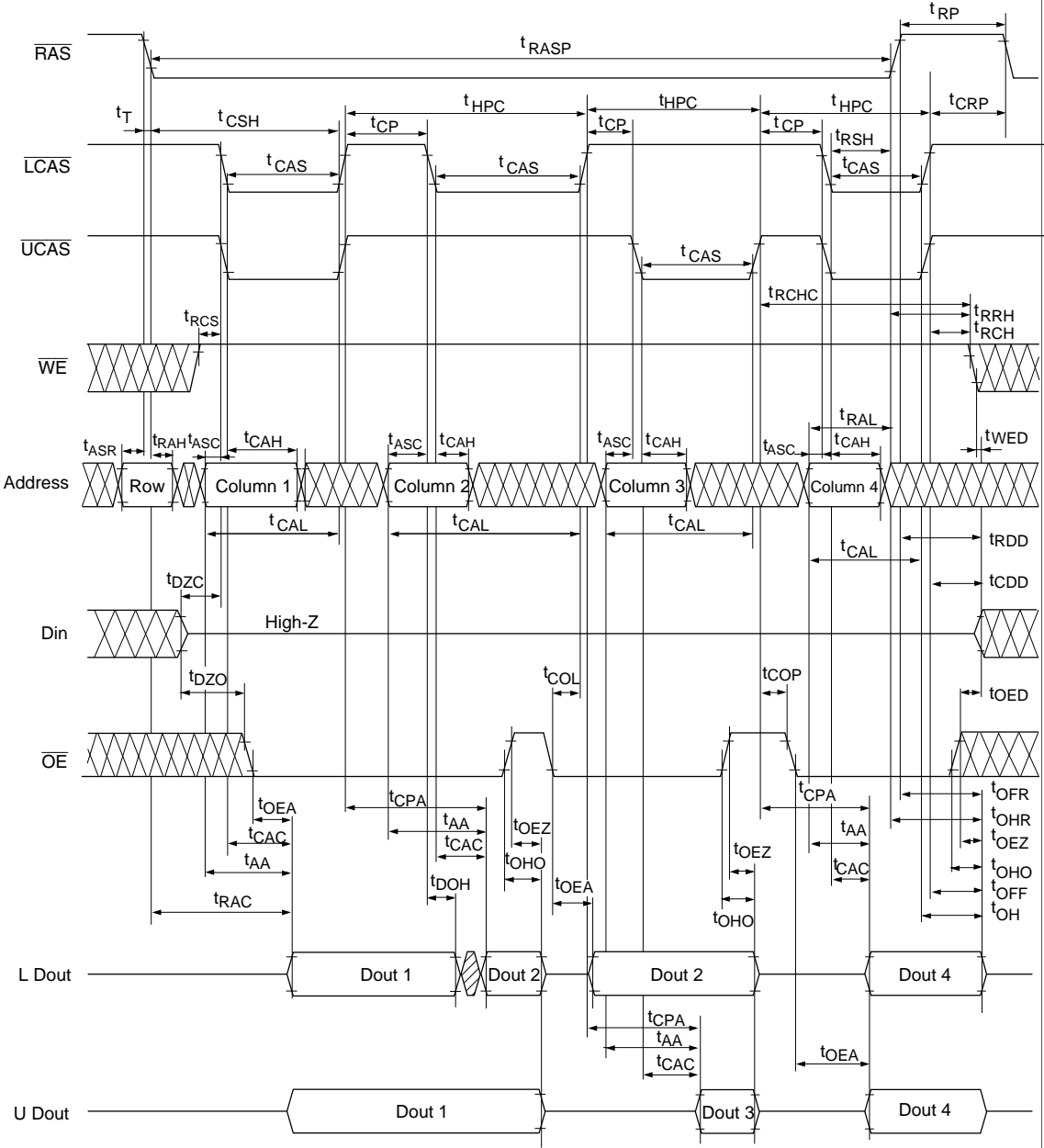

## EDO Page Mode Early Write Cycle

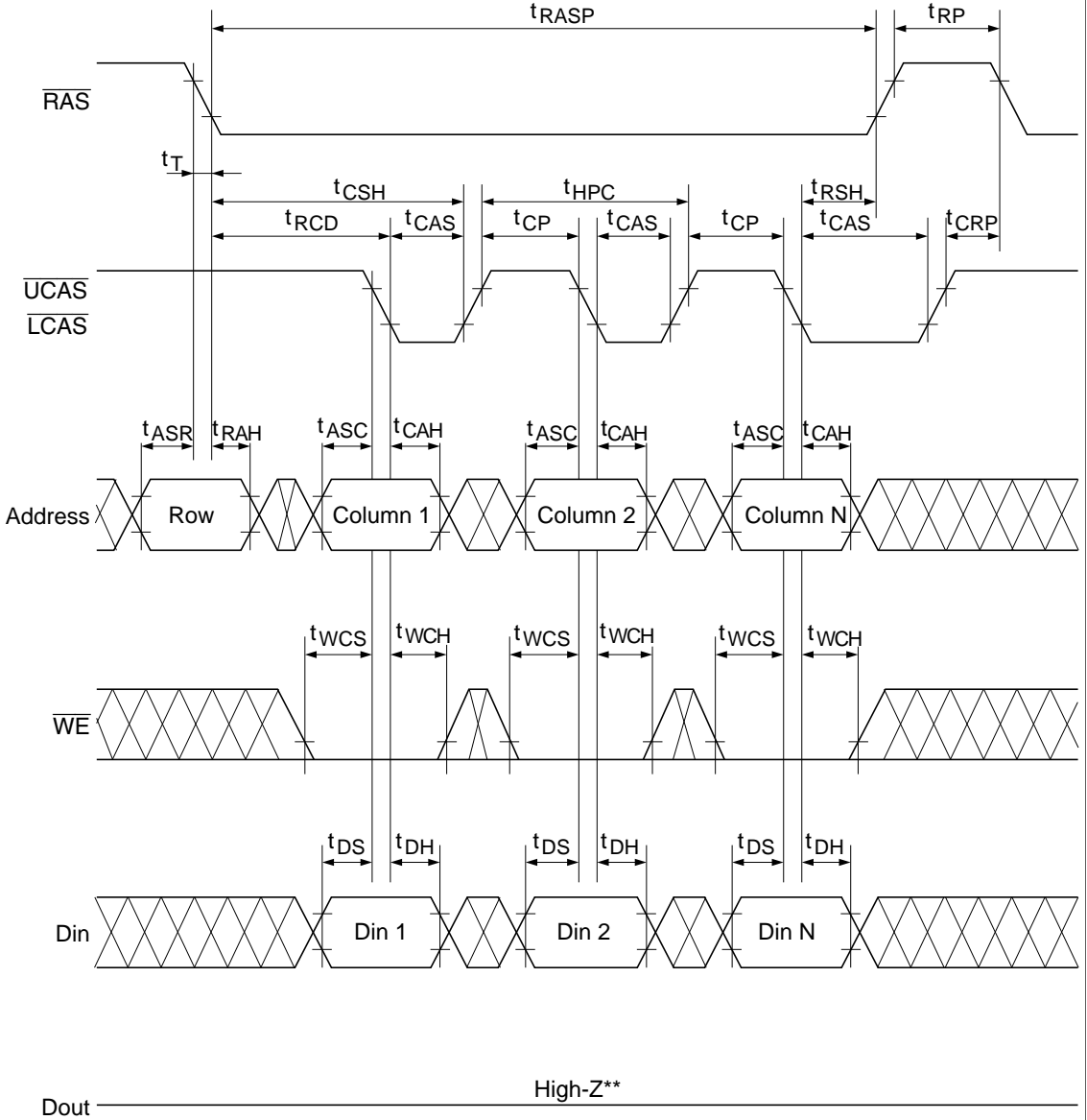

\*  $\overline{OE}$  : H or L

\*\*  $t_{wCS} \geq t_{wCS}(\text{min})$

# HM51W16165B Series, HM51W18165B Series

## EDO Page Mode Delayed Write Cycle\*18

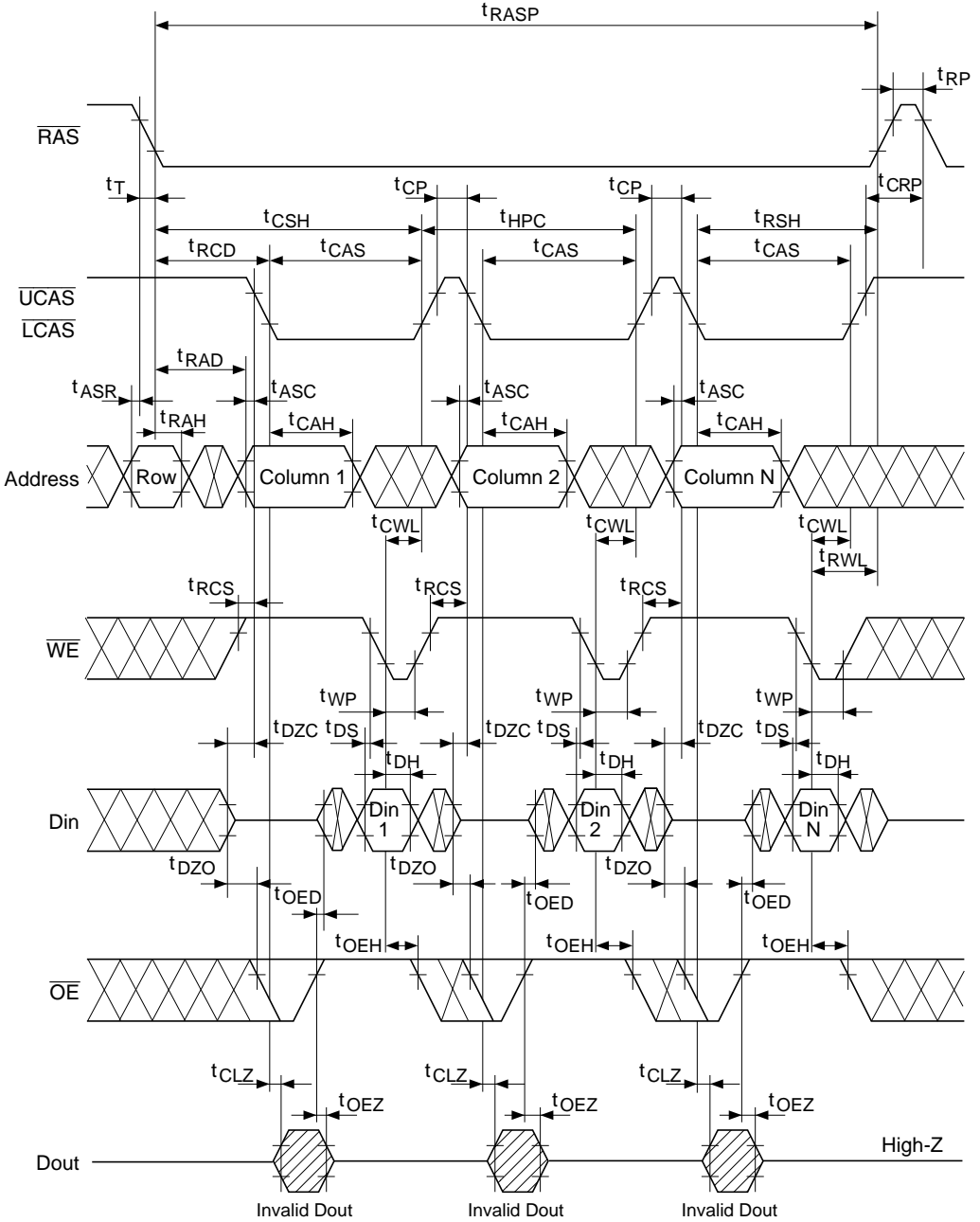

# HM51W16165B Series, HM51W18165B Series

## EDO Page Mode Read-Modify-Write Cycle\*18

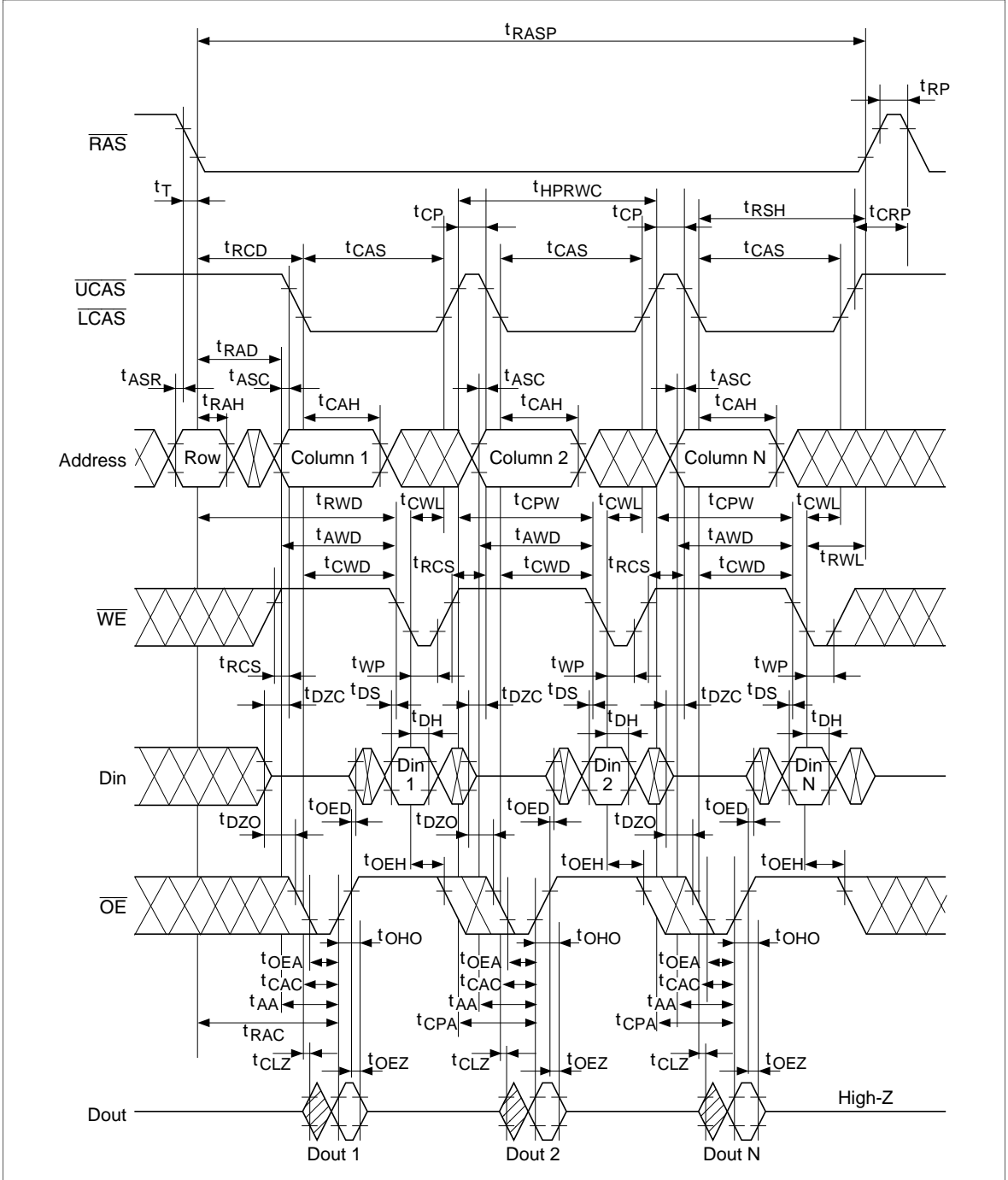

# HM51W16165B Series, HM51W18165B Series

## EDO Page Mode Mix Cycle (1)

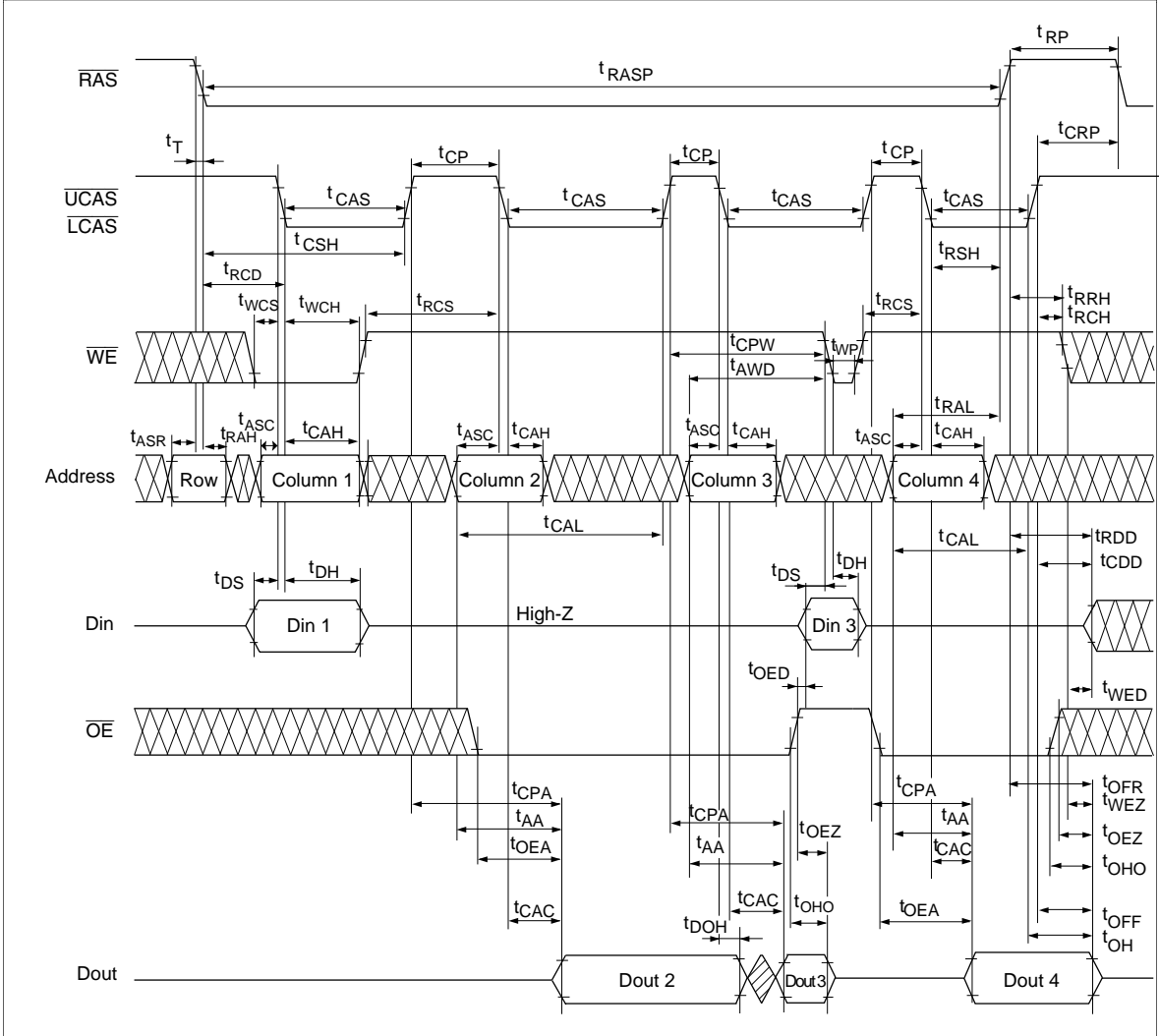

## EDO Page Mode Mix Cycle (2)

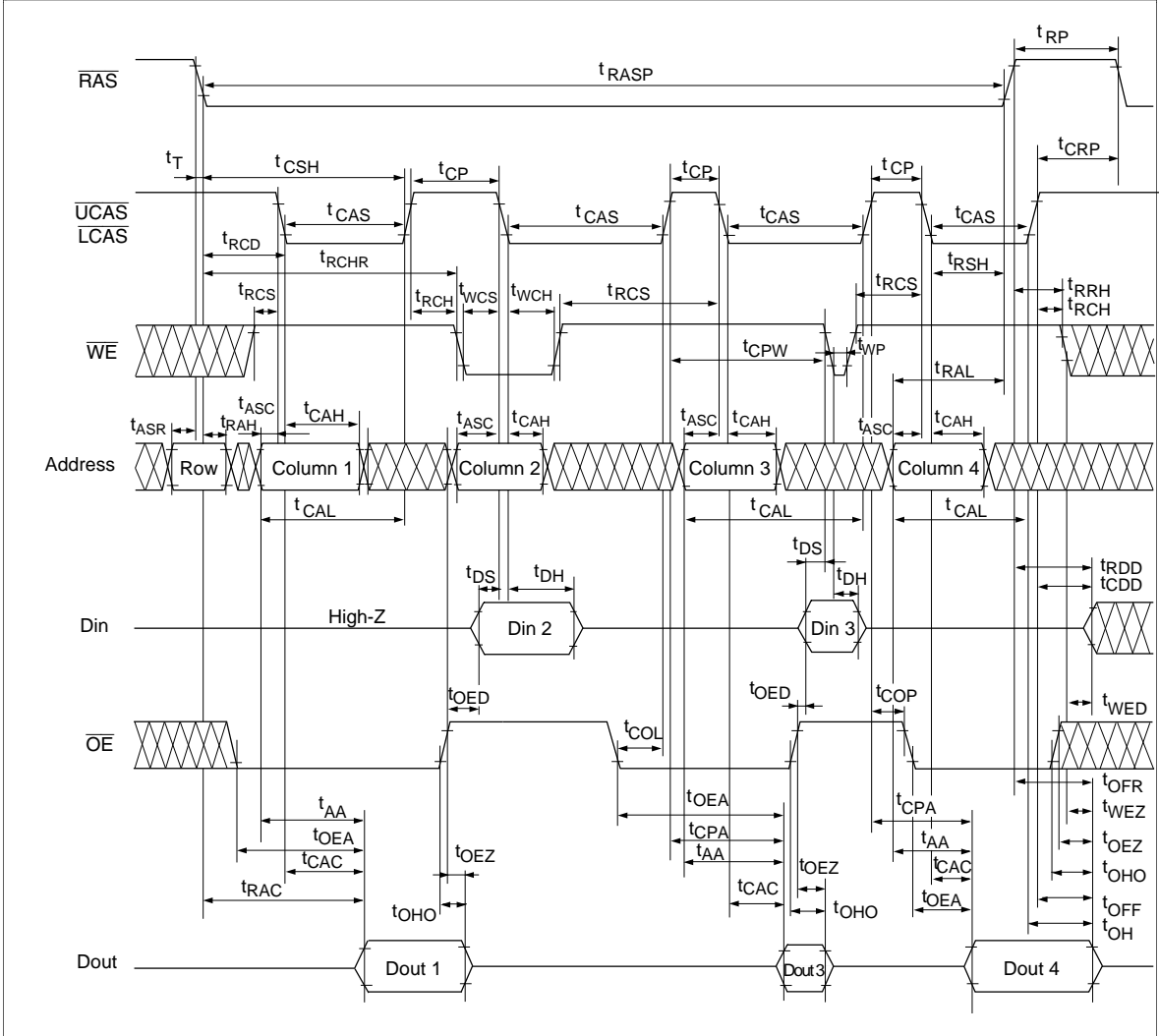

# HM51W16165B Series, HM51W18165B Series

Self Refresh Cycle (L-version)\*28, 29, 30, 31

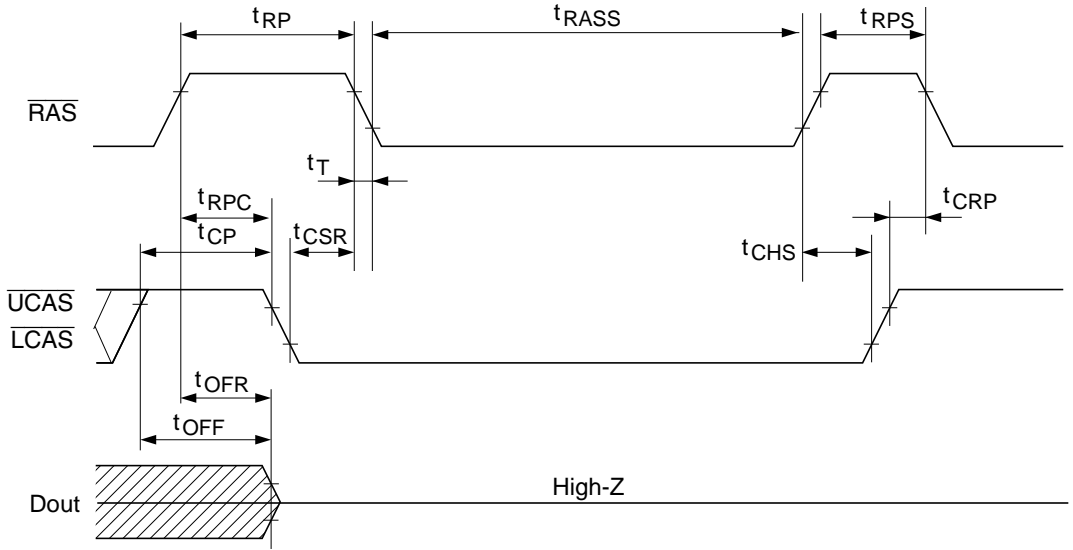

\*Address,  $\overline{OE}$ ,  $\overline{WE}$ : H or L



# HM51W16165B Series, HM51W18165B Series

## Package Dimensions

HM51W16165BJ/BLJ Series

HM51W18165BJ/BLJ Series (CP-42D)

Unit: mm

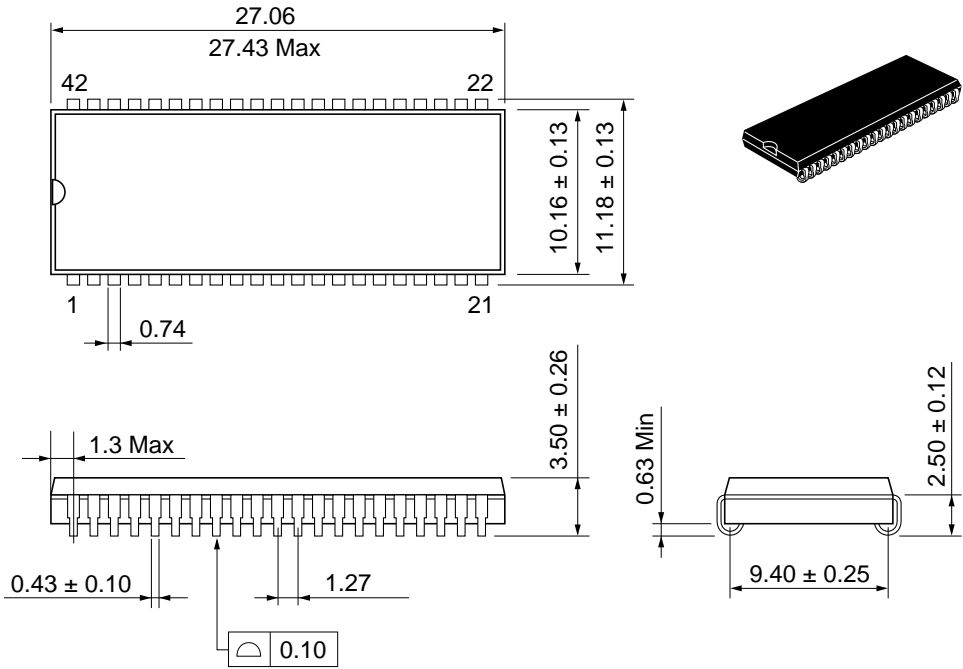

# HM51W16165B Series, HM51W18165B Series

HM51W16165BTT/BLTT Series

HM51W18165BTT/BLTT Series (TTP-50/44DC)

Unit: mm

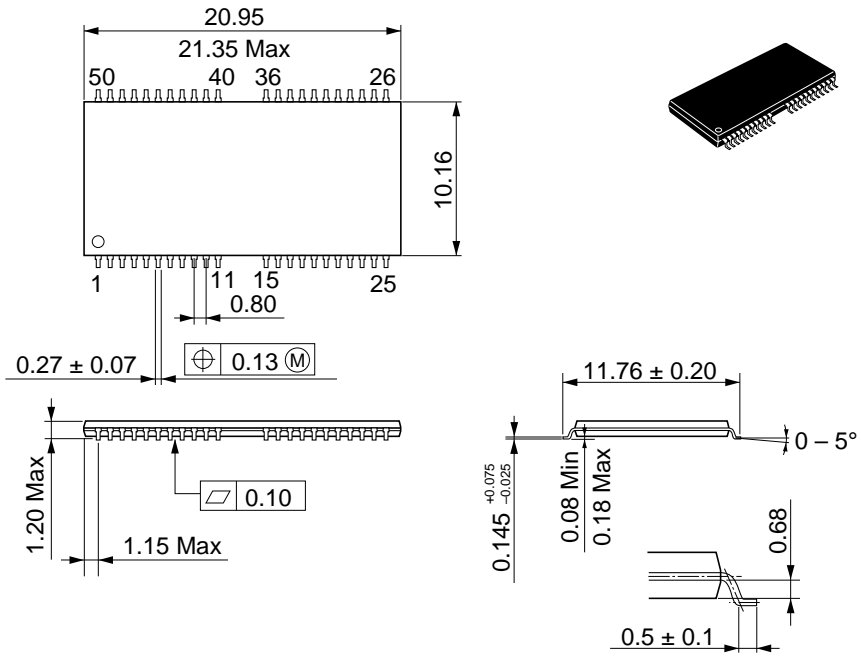

When using this document, keep the following in mind:

1. This document may, wholly or partially, be subject to change without notice.
2. All rights are reserved: No one is permitted to reproduce or duplicate, in any form, the whole or part of this document without Hitachi's permission.
3. Hitachi will not be held responsible for any damage to the user that may result from accidents or any other reasons during operation of the user's unit according to this document.
4. Circuitry and other examples described herein are meant merely to indicate the characteristics and performance of Hitachi's semiconductor products. Hitachi assumes no responsibility for any intellectual property claims or other problems that may result from applications based on the examples described herein.
5. No license is granted by implication or otherwise under any patents or other rights of any third party or Hitachi, Ltd.
6. **MEDICAL APPLICATIONS:** Hitachi's products are not authorized for use in **MEDICAL APPLICATIONS** without the written consent of the appropriate officer of Hitachi's sales company. Such use includes, but is not limited to, use in life support systems. Buyers of Hitachi's products are requested to notify the relevant Hitachi sales offices when planning to use the products in **MEDICAL APPLICATIONS**.

---

---

# HITACHI

## **Hitachi, Ltd.**

Semiconductor & IC Div.  
Nippon Bldg., 2-6-2, Ohte-machi, Chiyoda-ku, Tokyo 100, Japan  
Tel: Tokyo (03) 3270-2111  
Fax: (03) 3270-5109

### **For further information write to:**

Hitachi America, Ltd.  
Semiconductor & IC Div.  
2000 Sierra Point Parkway  
Brisbane, CA. 94005-1835  
U S A  
Tel: 415-589-8300  
Fax: 415-583-4207

Hitachi Europe GmbH  
Electronic Components Group  
Continental Europe  
Dornacher Straße 3  
D-85622 Feldkirchen  
München  
Tel: 089-9 91 80-0  
Fax: 089-9 29 30 00

Hitachi Europe Ltd.  
Electronic Components Div.  
Northern Europe Headquarters  
Whitebrook Park  
Lower Cookham Road  
Maidenhead  
Berkshire SL6 8YA  
United Kingdom  
Tel: 0628-585000  
Fax: 0628-778322

Hitachi Asia Pte. Ltd.  
16 Collyer Quay #20-00  
Hitachi Tower  
Singapore 0104  
Tel: 535-2100  
Fax: 535-1533

Hitachi Asia (Hong Kong) Ltd.  
Unit 706, North Tower,  
World Finance Centre,  
Harbour City, Canton Road  
Tsim Sha Tsui, Kowloon  
Hong Kong  
Tel: 27359218  
Fax: 27306071

---

# HM51W16165B Series, HM51W18165B Series

---

## Revision Record

---

Rev.	Date	Contents of Modification	Drawn by	Approved by
0.0	Mar. 20, 1996	Initial issue		

---